

GROSS VEHICLE WEIGHTS (SPECIAL COMMODITY ALLOWANCES IN PARENTHESES)

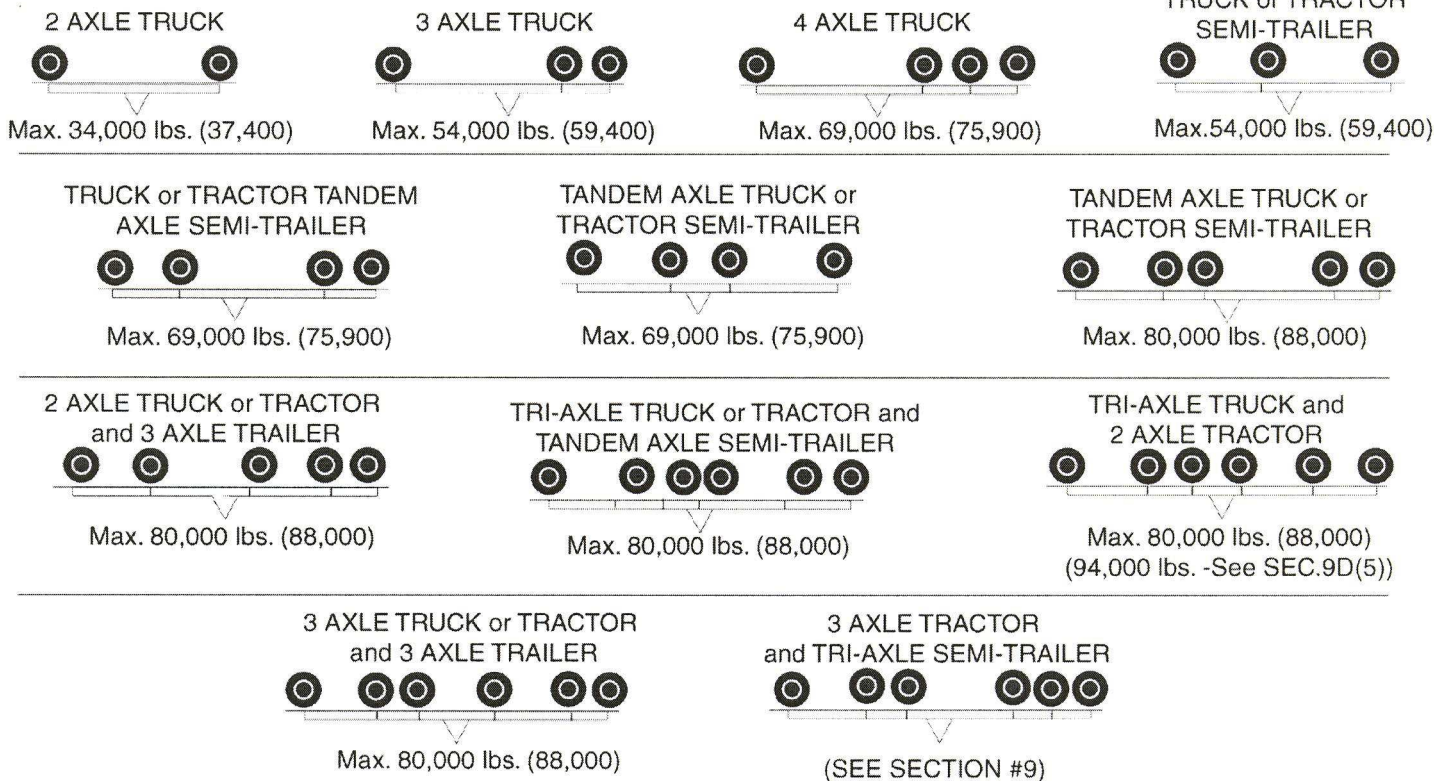

Gross weight limits on the Interstate for all vehicles and commodities are controlled by Bridge Formula (Table 3.) However, in no case shall the maximum G.V.W. on the Interstate exceed the limits established in Table 1.

GROSS VEHICLE DIMENSIONS

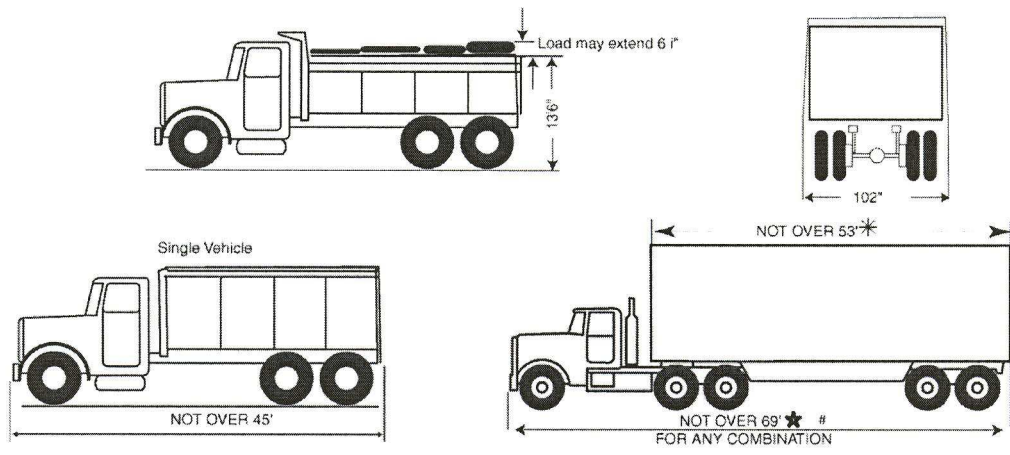

* If >45 to 48 feet, then the distance between the center of the rear axle of the tractor and the center of the rear axle of the trailer must not exceed 38 feet

Not over 74 feet if including a semitrailer > 48 feet long.

★ Tree length logs may extend 8 1/2 ft. beyond the vehicle provided the extension is not more than 25% of the log length. (NON-INTERSTATE)

INTERSTATE EXTENDED VEHICLE LENGTHS

Applies also to certain designated Federal Aid Primary highways and permitted access to that system of highways.

